

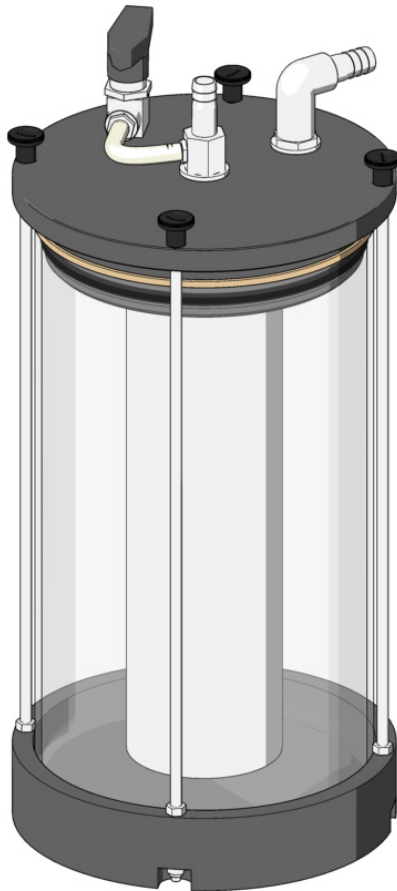

USER MANUAL
FILTRATION STATION
FOR FOOD LIQUIDS WITH SINGLE
FILTER



CONTENTS

1. General safety rules.....	4
2. Packing contents	6
3. Unpacking.....	6
4. Product description	7
5. Machine start	8
6. Tank emptying	10
7. Filter replacement	11
8. Maintenance	14
9. Disposal	15
10. Declaration of conformity.....	15
11. Warranty	16

1. GENERAL SAFETY RULES

Read all the instructions and safety warnings before use. Keep the manual for future reference.

All images are only indicative. Products may undergo future changes.

 This manual is an integral part of the filtration station and it must be read carefully before using it. indications with regards to its safe installation, use and maintenance. Keep it with care.

 Before using the filtering systems please read the following general safety rules carefully.

- After taking off the packaging make sure the filtration stations are intact. In case of doubt do not use them and contact an authorized service centre. Do not leave pieces of packaging (plastic bags, boxes, etc.) within the reach of children or disabled persons since they are potential sources of danger.
- This device is not intended for use by individuals (including children) with restricted physical, physiological or intellectual abilities or who are lacking in experience and/or knowledge unless they are supervised by a person responsible for their safety or receive from this person instruction in how the device is to be used. Children should be supervised to ensure that they do not play with the device.
- Put the device on a stable and dry surface.
- Do not locate the device in places exposed to direct sunlight.
- Do not obstruct the device with objects while it is working.
- Do not expose the device to wind, rain and water splashes.
- Never immerse the device in water or other liquids.
- Never use metal or abrasive sponges to clean the device.
- Supervise children to prevent them from playing with the Ultrafiller filling machine.
- The device must be used in domestic or similar environments (work places, hotels, motels and similar facilities). The device is not conceived for industrial use.
- Contact the Customer Care Technical Service to repair or replace damaged cables and/or faulty devices.
- Do not open the device casing or repair the device yourself. Should you do so, the safety of the device may be compromised and the warranty becomes void.
- NEVER submerge the device in water; wipe it with a slightly damp cloth only.

 **WARNING**

The original configuration of the device must not be changed at all.
On receiving the device, make sure the supply corresponds to what has been ordered.
In case of non-compliance immediately inform the manufacturer.
Also make sure the device has not been damaged during transport.

The Industria di Leivi products have not been conceived to work in areas at risk of explosions and at high risk of fire. In case of damage or malfunction, the Ultrafiller must not be used until the Customer Care Technical Service has repaired it.

Customer Care Technical Service

RESELLER STAMP

2. PACKING CONTENTS

The filtration station is delivered in a box containing:

1. Filtration station
2. 3/8" inlet and outlet hoses
3. Instruction manual

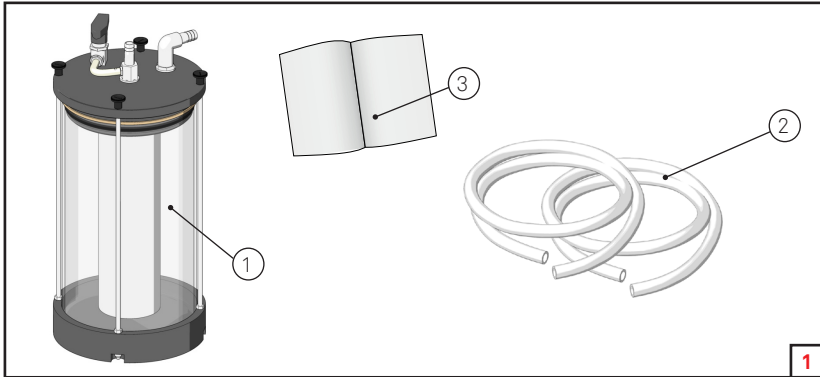

3. UNPACKING

1. Remove the device from the box.
2. Remove all the components from the box.

WARNING

Do not permit small children to play with plastic bags.
There is a risk of suffocation!

Check the device

Before using the device, check that all of the items listed have been delivered and that there are no visible signs of damage.

NOTE

The filtration station must be cleaned and sanitized before any use.

4. PRODUCT DESCRIPTION

The filtration station has been designed to filter the food liquids during the bottle filling. The liquid goes into the filtration station through the pressure drop generated by the bottling machine (no included).

The filtration station is made up of the following main parts:

1. Liquid inlet union
2. Liquid outlet union
3. Bypass valve
4. Pyrex cylinder
5. Filter

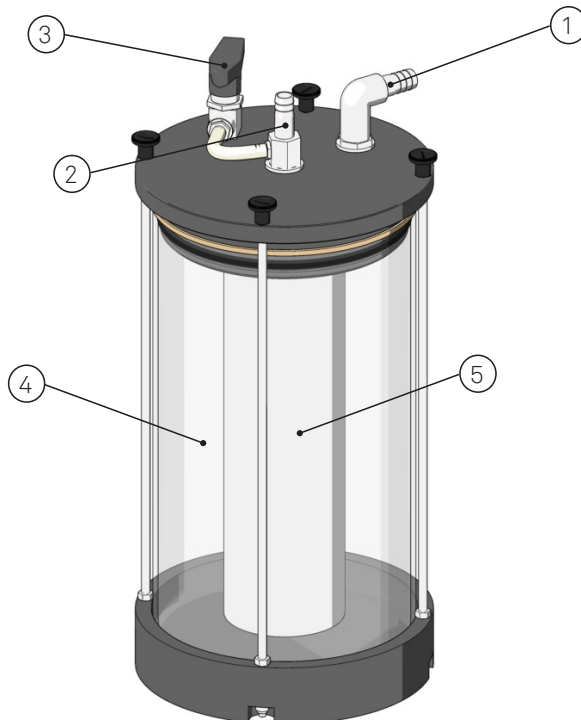

 **WARNING**

To make the liquid go through use only hoses for food use at a maximum temperature of 80° C.

5. MACHINE START

POSITIONING

Position the filtration station on a flat surface away from heating sources. Make sure the machine is properly levelled. If not, adjust it.

FILTERING POSITION

Insert the filter into its seat and rotate it clockwise by 90°, then lock it through the proper retainers "1" (see pict. 2). The filters are sold separately. Enable the filling machine and start the filling (see the corresponding manual).

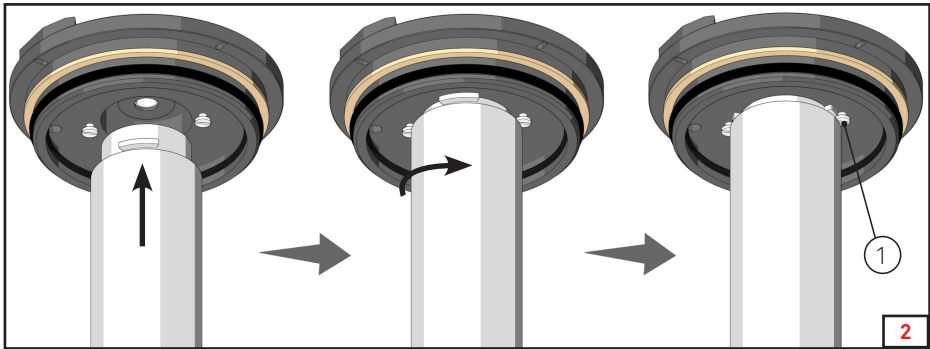

INLET AND OUTLET HOSE CONNECTION

Connect the inlet and outlet hoses to the corresponding hose holders (see pict. 3).

Check the right connection of the outlet hose to the filling machine (not included - see the corresponding manual).

The filtration station can be connected to the ultrafiller 1 as indicated in the picture (see pict.4)

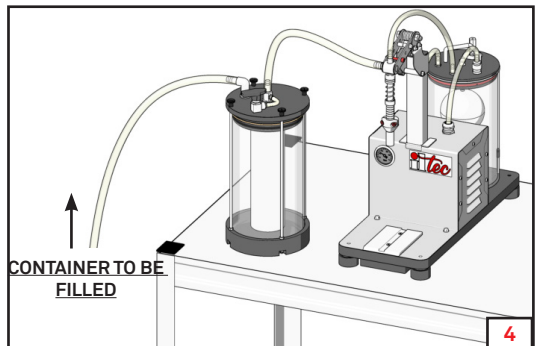
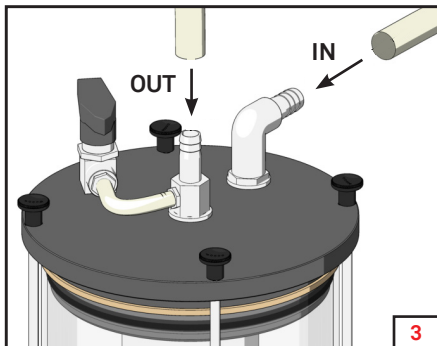

FILTRATION STATION OPERATION

After positioning the filter and connecting the filtration station to the Ultrafiller 1 filling machine, proceed as follows:

1. Open the filter holder bypass valve “1”
2. Enable the filler
3. As soon as the liquid reaches the transparent pipe “2”, close the valve. From now on, the filter “3” is operative.

NOTE

Repeat this operation every time the filter is empty.

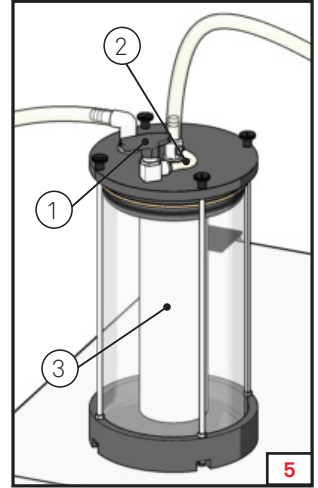

6. TANK EMPTYING

At the end of the filling drain the liquid contained in the station.

1. Switch off the filler by turning the main switch to OFF.
2. Remove vacuum from the filler.
3. Remove the locking knobs "3" (see pict. 6).
4. Lift the cover with filter (see pict. 7).
5. Empty the tank.

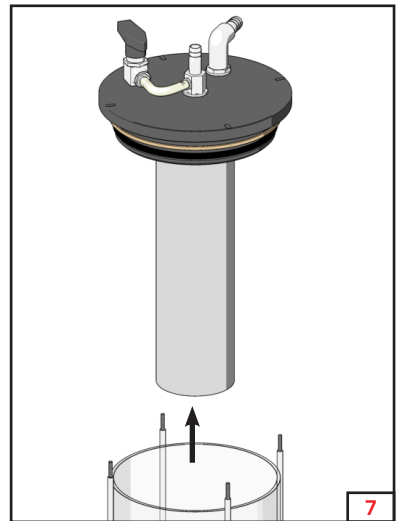
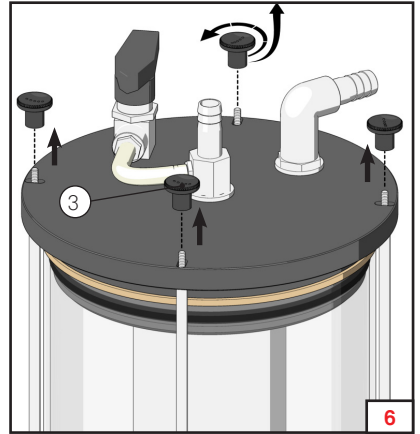

7. FILTER REPLACEMENT

When the filters are clogged, the filtering cartridgeges must be replaced. To replace them proceed as follows:

1. Remove the product inlet/outlet pipes (see pict. 8).

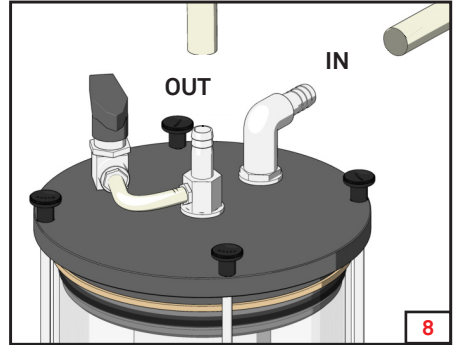

2. Remove the four locking knobs "3" (see pict. 9).

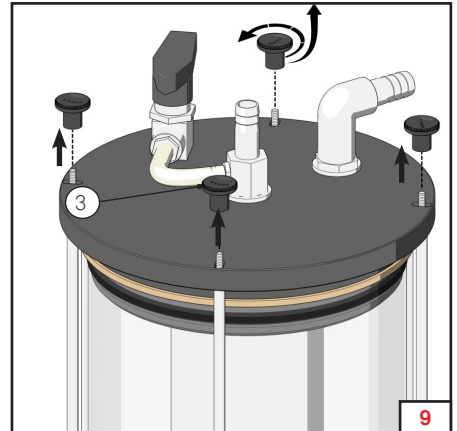

3. Lift the cover complete with filters (see pict. 10).

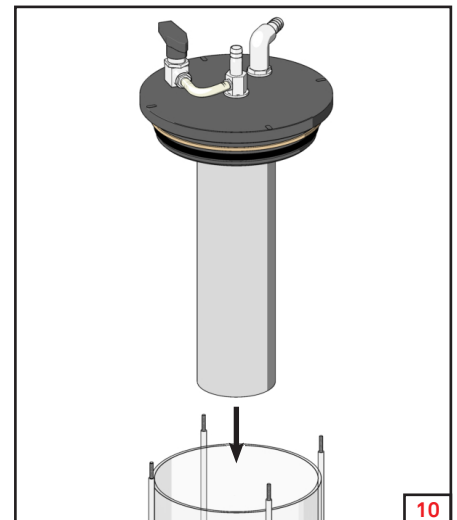

4. Remove the filter from its seat by rotating clockwise by 90°, then replace it with the new filter (see pict. 11).

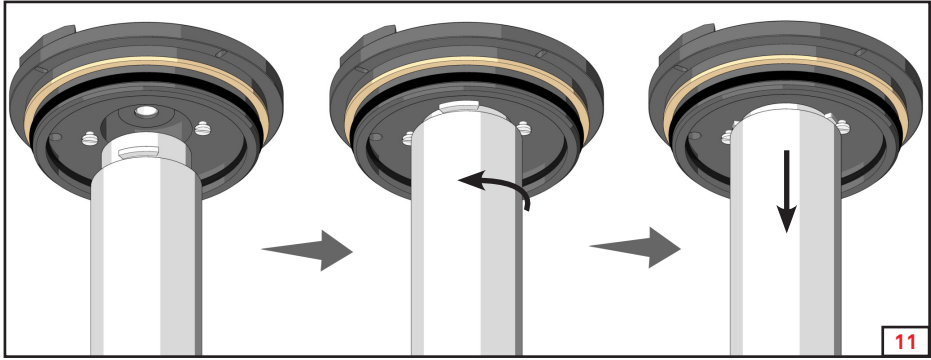

5. Reposition the new filter and block it through the proper retainers "4" (see pict.12).

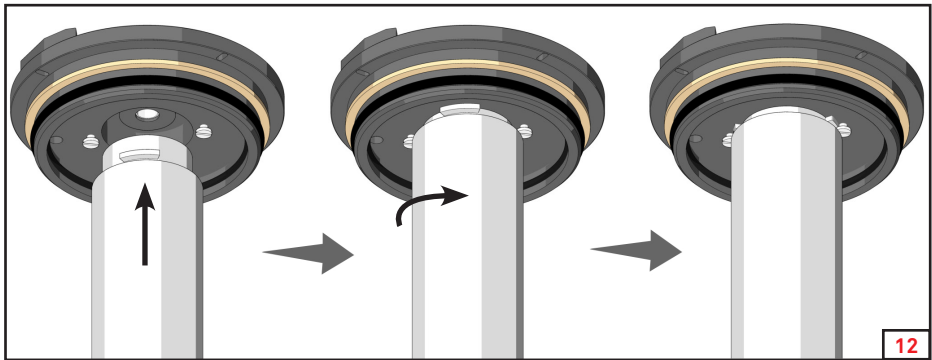

6. Reposition the cover complete with filters on the tank (see pict. 13).

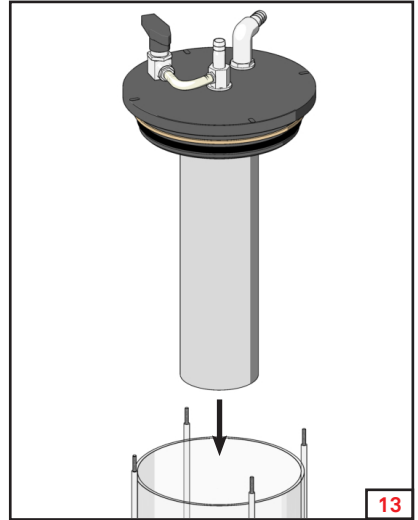

7. Fix the cover through the 4 locking knobs "3" (see pict.14).

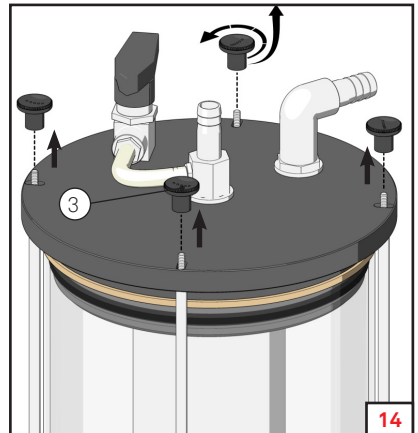

8. MAINTENANCE

CLEANING

For a deep cleaning remove the hoses and clean the unions by means of a brush.

1. Remove the four locking knobs “3” (see pict. 13) and move upwards the cover complete with filters (see pict. 16).
2. Then clean and dry the machine thoroughly.

WARNING

Do not use soaps and/or foamy products.

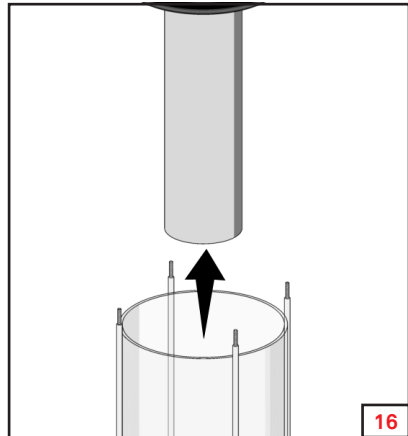
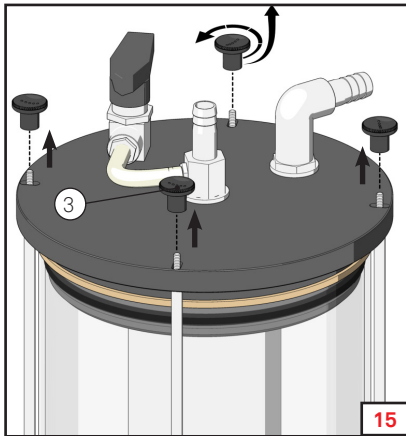

SPARE PARTS

NOTE

To use the filtration station correctly, use original spare parts only.

Upon request, the following components can be supplied:

- food hoses
- pyrex cylinder

The filtering cartridges are sold separately.

9. DISPOSAL



If the picture on the left (a cross-out wheel bin) appears on the product, the European directive 2012/19/EU applies. These products cannot be disposed of with normal waste. Please, inquire about the regulations in force relating to the separate collection of electric and electronic equipment. Do not dispose of old equipment with household waste. The adequate collection of old equipment contributes to prevent possible negative effects on the planet and on people health. The recycling of materials helps to reduce the consumption of raw materials.

10. DECLARATION OF CONFORMITY



Manufacturer: Industria di Leivi - Via Gazzo, 1 - 16040 Leivi (GE) - Italy

We hereby declare that the machine provided with CE marking complies with the following Directives:

- Regolamento 1935/2004/CE
- Regolamento 2023/2006/CE

11. . WARRANTY

The filtration stations by Industria di Leivi have a 12 month warranty from the purchase date, except in case of different written agreements.

The warranty covers all manufacturing and material defects. Replacement and repair operations are covered only if carried out at the manufacturer workshop . **If in-warranty goods need to be repaired, the customer must always send the whole Ultrafiller filling machines to the manufacturer. Single units will not be repaired under warranty.**

The material to be repaired must be sent CARRIAGE FREE.

Once the machine has been repaired, it will be sent CARRIAGE FORWARD to the customer.

The warranty covers neither interventions on site by our technicians nor the device disassembly from the installation place.

The warranty does not include:

- ☞ failure caused by wrong use or assembly;
- ☞ failure caused by external agents;
- ☞ failure caused by lack of maintenance or negligence.

WARRANTY FORFEITURE:

- ☞ in case of arrearage or other breaches of contract;
- ☞ whenever changes or repairs are carried out on our equipment without our prior authorization;
- ☞ whenever the damage is caused by improper use, bad treatment, bumps, falls and other causes not due to normal working conditions;
- ☞ whenever the unit has been tampered with, dismantled or previously repaired by unauthorized staff;
- ☞ in case the filling machines are used for purposes that are different from the ones described in this manual.

All repair operations carried out under warranty do not interrupt its duration.

All disputes will be settled in the court of justice of Genoa (Italy).

We thank you in advance for the attention you will pay to this manual and we invite you to inform us of any change you deem necessary to improve it and make it more complete.

